

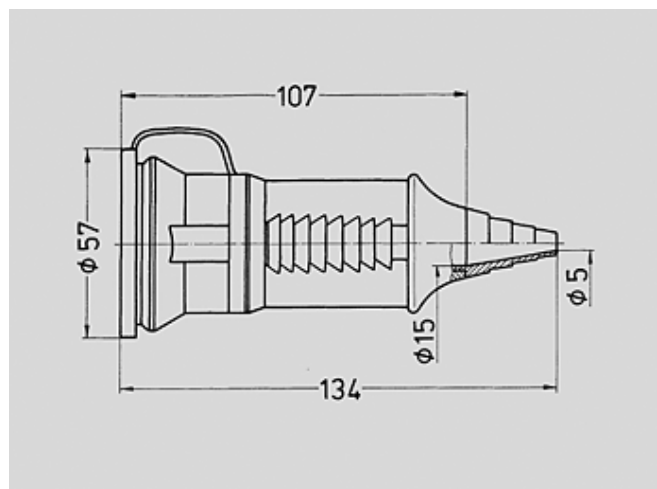

N° de Ref. : 10751

**Prolongador
SCHUKO®**16A
2P+T
230Vcon protección contra deformaciones del cable y tapa, para cables de hasta 3 x 2,5 mm², hasta H07RN-FPlano 3 MB 39
Dim. en mmGrupo de artículos : **3927**

SCHUKO IP protection types : IP44

packing unit : 0010

Peso : 75 g

N° DE REF.

SCHUKO colour	N° de Ref.
blue / blue-grey (standard)	10843
grey	10751
black	10755
orange	10842
red	10844
yellow	10845
green	10846