

Control Units CU240B-2, CU240E-2

Overview



Control Unit CU240E-2 DP-F

The converter is controlled by the Control Unit. Besides the control, further functions are provided which can be adjusted to the relevant application by setting the corresponding parameters.

The different Control Unit series versions include:

- CU240B-2 series with standard I/O structure. Sufficient for numerous applications.
- CU240E-2 series with extended I/O structure and integrated safety technology.

The Control Units CU240B-2 and CU240E-2 can be operated with the following Power Modules:

- PM240
- PM250
- PM260

Selection and ordering data

Communication	Digital inputs Standard	Digital inputs Fail-safe	Digital outputs	Encoder interfaces	Designation	Control Unit Order No.
Basis						
RS485/USS	4	–	1	–	CU240B-2	6SL3244-0BB00-1BA1
PROFIBUS DP	4	–	1	–	CU240B-2 DP	6SL3244-0BB00-1PA1
Standard						
RS485/USS	6	1 F-DI (opt. per 2 DI)	3	–	CU240E-2	6SL3244-0BB12-1BA1
PROFIBUS DP	6	1 F-DI (opt. per 2 DI)	3	–	CU240E-2 DP	6SL3244-0BB12-1PA1
Fail-safe version						
RS485/USS	6	3 (opt. per 2 DI)	3	–	CU240E-2 F	6SL3244-0BB13-1BA1
PROFIBUS DP	6	3 (opt. per 2 DI)	3	–	CU240E-2 DP-F	6SL3244-0BB13-1PA1

Safety Integrated functions

The basic version of the CU240E-2 series (CU240E-2 and CU240E-2 DP) includes the safety function "Safe Torque Off" (STO) (certified according to EN 954-1, Category 3 and IEC 61508 SIL 2 as well as ISO 13849-1 PLd).

The following extended Safety Integrated functions have been integrated in the Control Units CU240E-2 F and CU240E-2 DP-F.

- Safe Torque Off (STO) protects the unit against an active drive movement
- Safe Stop 1 (SS1, 1) for continuous monitoring of the safe braking ramp
- Safely Limited Speed (SLS) protects the unit against hazardous movements when exceeding a limit speed (the Control Units CU240E-2 DP-F features up to 4 selectable SLS)
- Safe Direction (SDI). This function ensures that the drive can only rotate in the selected direction.
- Safe Speed Monitoring (SSM). This function outputs a message if a drive is operated below a specified speed / feed rate.

Both the function "Safe Stop 1" (SS1) and the function "Safely Limited Speed" (SLS) can be operated without motor encoder or encoder; minimal expenditure is required for implementation. In particular already existing systems can be conveniently retrofitted to safety technology without having to modify the motor or mechanics.

The STO function can be used for all applications without restrictions. The functions SS1, SLS, SDI and SSM are permissible for all applications where the load is not accelerated after deactivating the frequency converter. They are thus not permissible for applications with pulling loads such as hoisting gear or unwinders.

Further information is included in the [Chapter Highlights, Section Safety Integrated](#).

Configuration

Control Units CU240B-2, CU240B-2 DP



Control Unit CU240B-2 with closed and open terminal covers

Terminal no.	Signal	Characteristics
Digital inputs (DI)		
5 ... 8	DI0 ... DI3	Freely programmable (electrically isolated) 5.5 mA/24 V
69	DI COM	Reference potential for digital inputs
Digital output (DO)		
18	DO0, NC	Relay output DO0 NC contact (0.5 A, DC 30 V)
19	DO0, NO	Relay output DO0 NO contact (0.5 A, DC 30 V)
20	DO0, COM	Relay output DO0 Common contact (0.5 A, DC 30 V)
Analog input (AI)		
3	AI0+	0 ... 10 V, -10 ... +10 V, 0/2 ... 10 V or 0/4 ... 20 mA
4	AI0-	Relay output 3 NC contact (0.5 A, DC 30 V)
Analog output (AO)		
12	AO0+	Freely programmable (0/4 ... 20 mA with max. 500 Ω 0/2 ... 10 V with min. 500 Ω)
13	AO0-	M
PTC / KTY Interface		
14	PTC+	Positive PTC/KTY- input
15	PTC-	Negative PTC/KTY- input
Power supply		
9	+24 V OUT	Electrically isolated operator power supply +24 V bei 100 mA
1	+10 V OUT	Not electrically isolated controlled 10 V power supply for I/OS – max. 10 mA
2	GND	Common reference potential
28	GND	Common reference potential
31	+24 V IN	Power supply input DC 18 ... 30 V, max. 1500 mA
32	GND IN	Reference potential for terminal 31

Control Units CU240E-2, CU240E-2 DP, CU240E-2-F and CU240E-2 DP-F



Control Unit CU240E-2 with closed and open terminal covers

Terminal no.	Signal	Characteristics
Digital inputs (DI) – Standard		
5 ... 8, 16,17	DI0 ... DI5	Freely programmable (electrically isolated) 5.5 mA/24 V
69	DI COM1	Reference potential for digital inputs 0, 2, 4, 6
34	DI COM2	Reference potential for digital inputs 1, 3, 5, 7
Digital inputs (DI) – Fail-safe (formed from two standard inputs through parameterization)		
16, 17	F-DI0	Fail-safe digital inputs, 2-channel (redundant), Freely programmable (electrically isolated) 5.5 mA/24 V
The following are only used with CU240E-2 F and CU240E-2 DP-F		
5, 6	F-DI1	Fail-safe digital inputs, 2-channel (redundant), Freely programmable (electrically isolated) 5.5 mA/24 V
7, 8	F-DI2	Fail-safe digital inputs, 2-channel (redundant), Freely programmable (electrically isolated) 5.5 mA/24 V

Terminal no.	Signal	Characteristics
Digital outputs (DO)		
18	DO0, NC	Relay output DO0 NC contact (0.5 A, DC 30 V)
19	DO0, NO	Relay output DO0 NO contact (0.5 A, DC 30 V)
20	DO0, COM	Relay output DO0 Common contact (0.5 A, DC 30 V)
21	DO1+	Transistor output DO1 Positive (0.5 A, DC 30 V)
22	DO1-	Transistor output DO1 Negative (0.5 A, DC 30 V)
23	DO2, NC	Relay output DO2 NC contact (0.5 A, DC 30 V)
24	DO2, NO	Relay output DO2 NO contact (0.5 A, DC 30 V)
25	DO2, COM	Relay output DO2 Common contact (0.5 A, DC 30 V)
Analog inputs (AI)		
3	AI0+	-10 ... 10 V, 0/4 ... 20 mA or digital input 6
4	AI0-	Reference potential for analog input 0
10	AI1+	-10 ... 10 V, 0/4 ... 20 mA or digital input 7
11	AI1-	Reference potential for analog input 1
Analog outputs (AO)		
12	AO0+	Freely programmable (0 ... 10 V, 0 ... 20 mA with max. 500 Ω)
13	AO GND	Reference potential for analog outputs
26	AO1+	Freely programmable (0 ... 10 V, 0 ... 20 mA with max. 500 Ω)
27	AO GND	Reference potential for analog outputs
PTC /KTY interface		
14	PTC+	Positive PTC/KTY input
15	PTC-	Negative PTC/KTY input
Power supply		
9	+24 V OUT	Electrically isolated operator power supply +24 V bei 200 mA
1	+10 V OUT	Not electrically isolated controlled 10 V power supply for I/OS – max. 10 mA
2	GND	Common reference potential
28	GND	Common reference potential
31	+24 V IN	Power supply input DC 18 ... 30 V, max. 1500 mA
32	GND IN	Reference potential for terminal 31

Integration

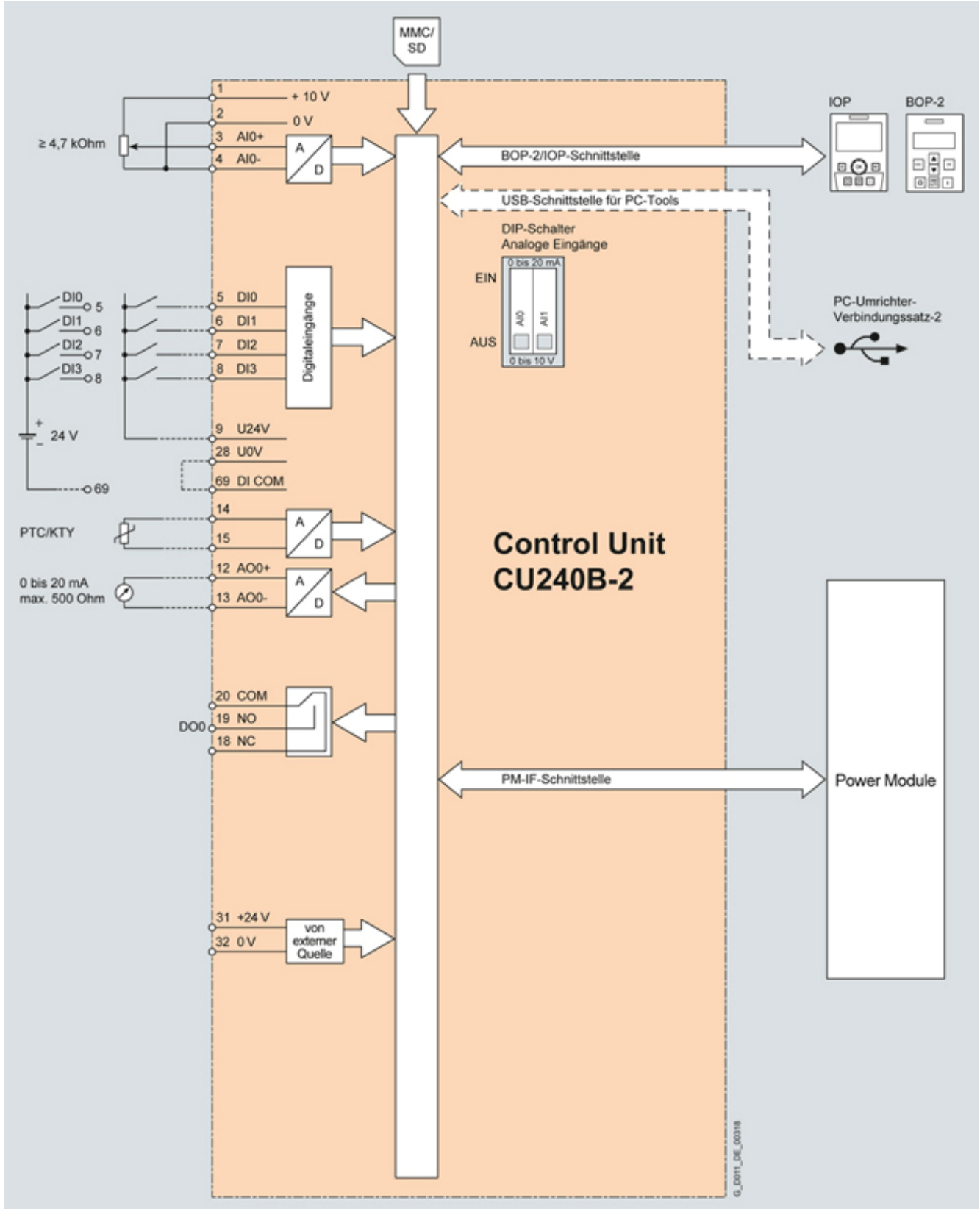

Wiring diagram for Control Unit CU240B-2

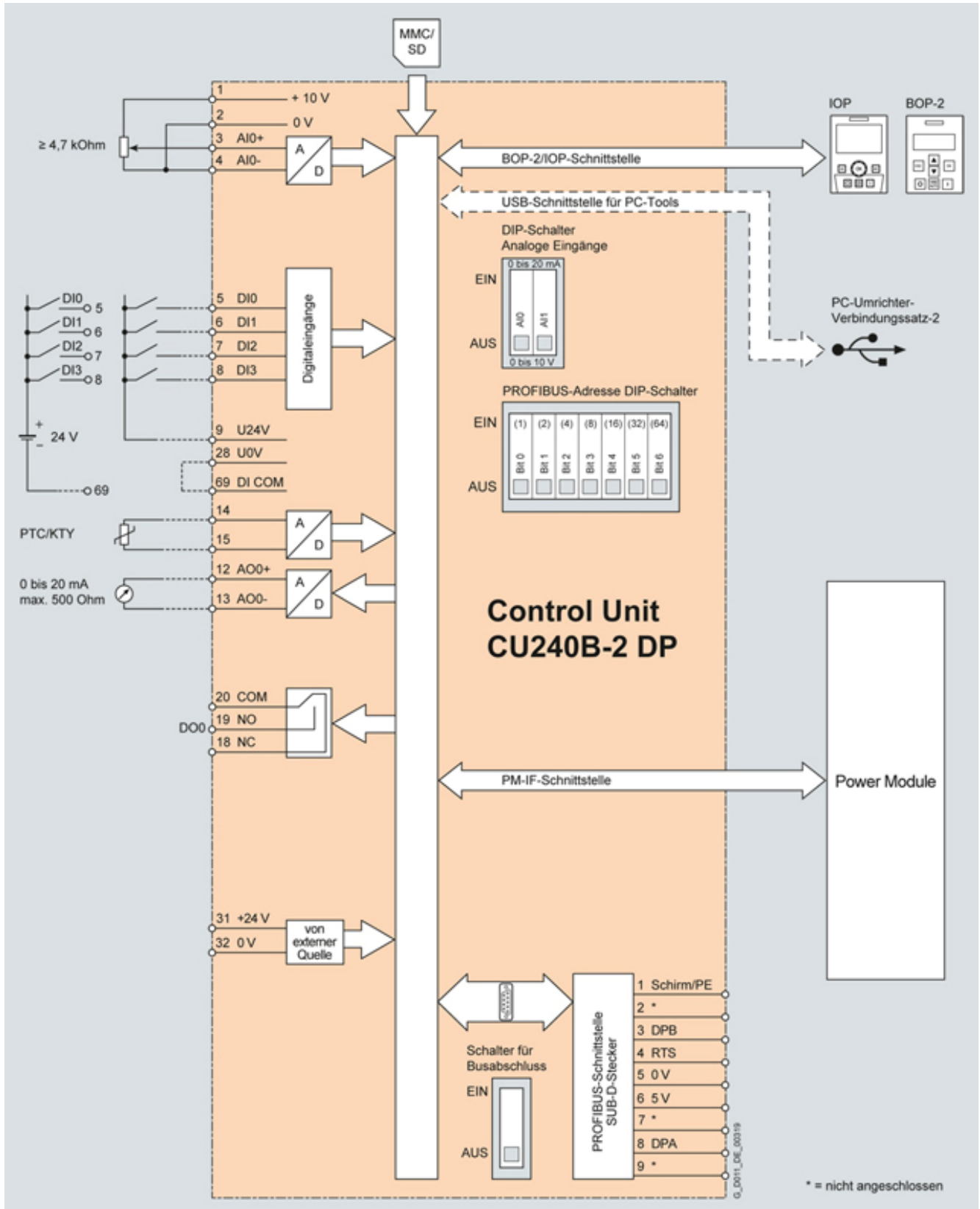

Wiring diagram for Control Unit CU240B-2 DP

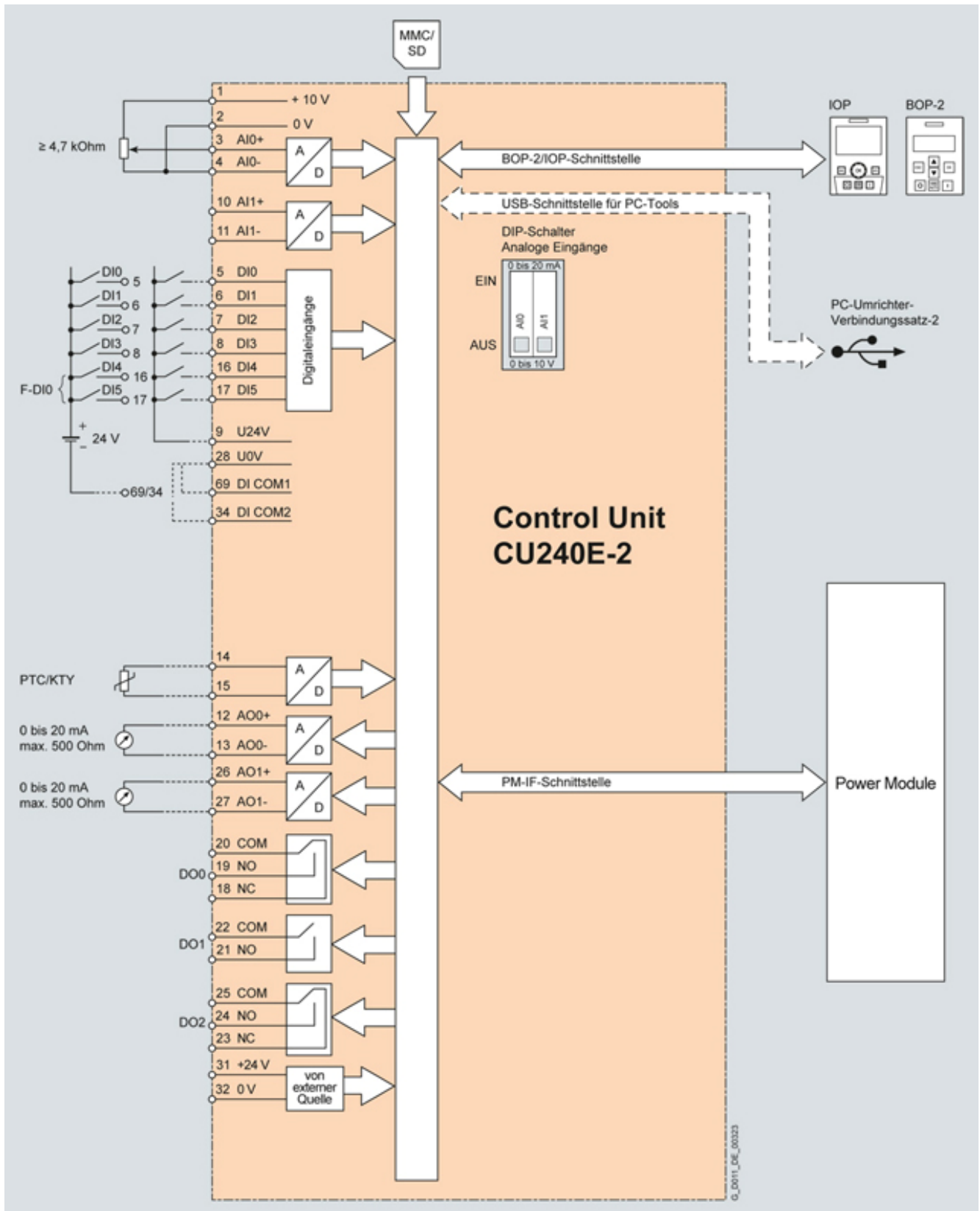

Wiring diagram for Control Unit CU240E-2

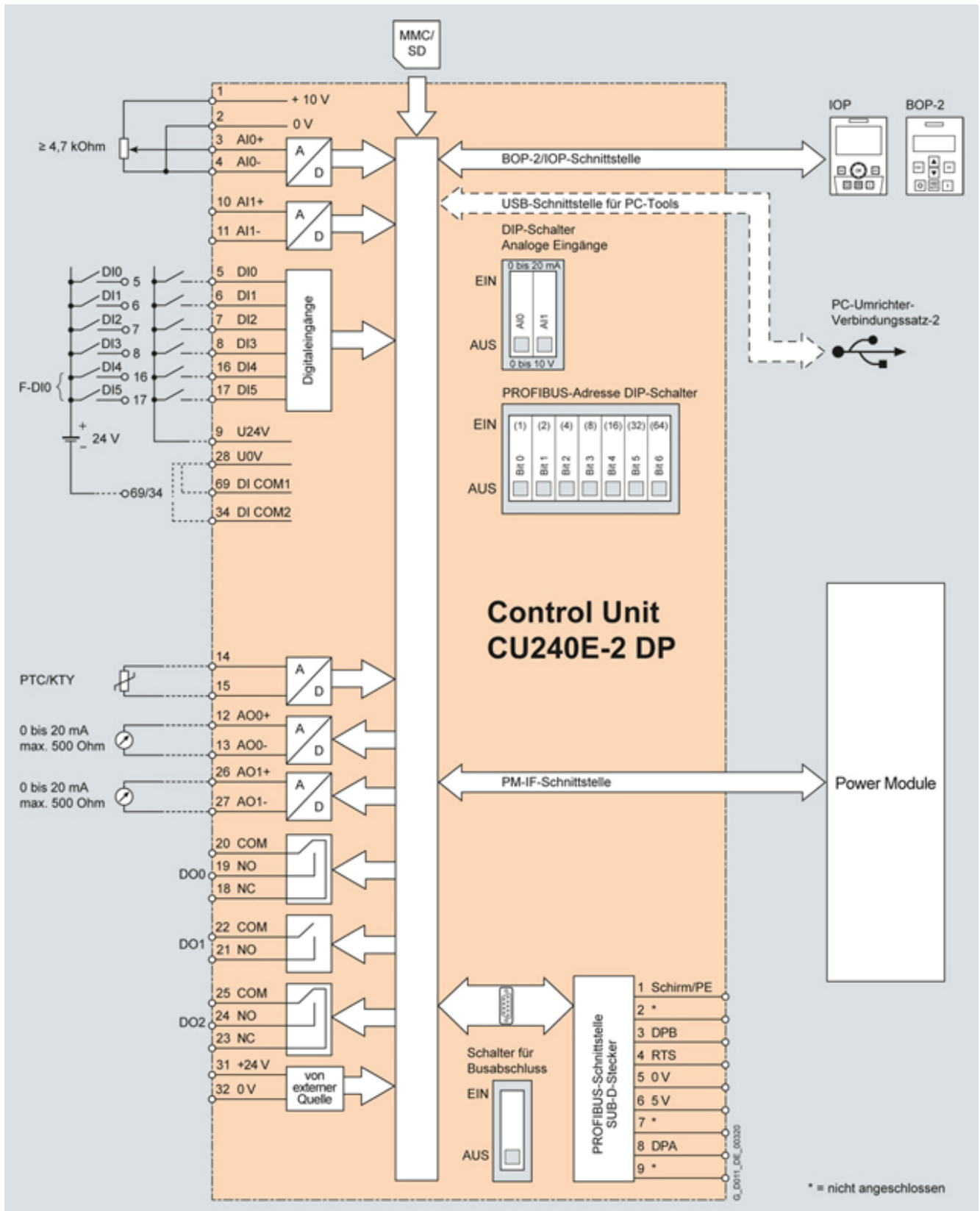

Wiring diagram for Control Unit CU240E-2 DP

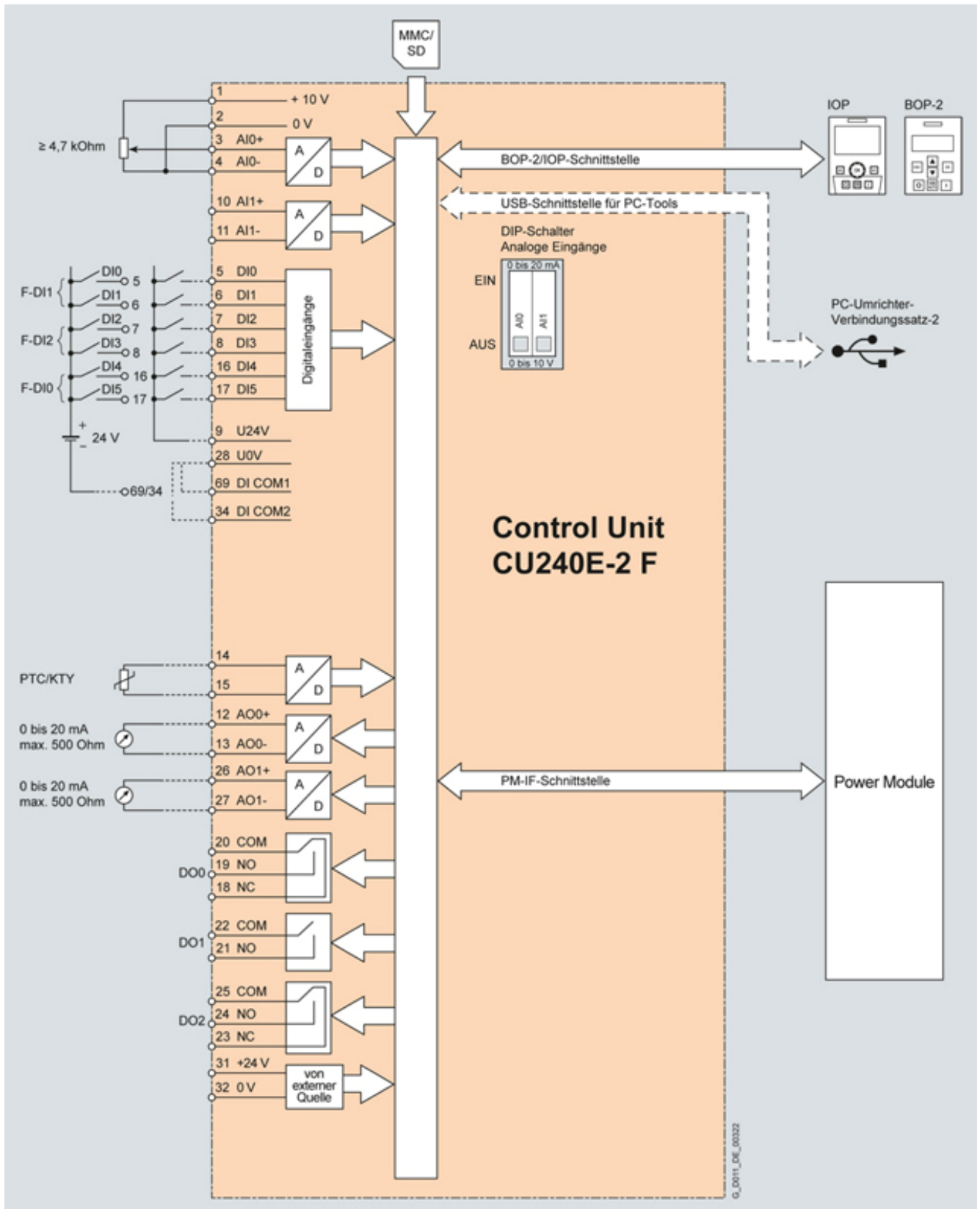

Wiring diagram for Control Unit CU240E-2 F

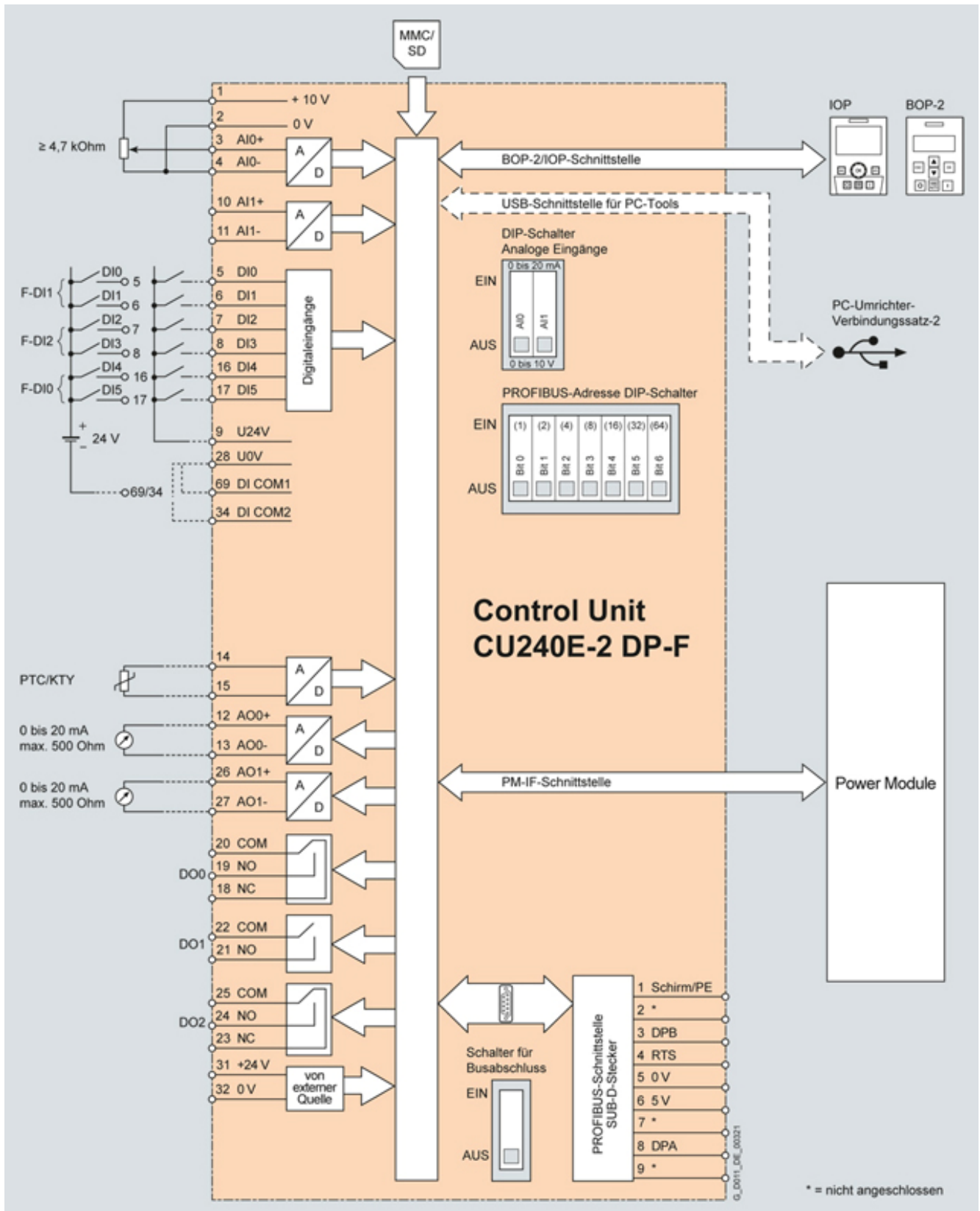

Wiring diagram for Control Unit CU240E-2 DP-F

Technical data

Control Unit	CU240B-2	CU240B-2 DP	CU240E-2	CU240E-2 DP	CU240E-2 F	CU240E-2 DP-F
	6SL3244-0BB00-1BA1	6SL3244-0BB00-1PA1	6SL3244-0BB12-1BA1	6SL3244-0BB12-1PA1	6SL3244-0BB13-1BA1	6SL3244-0BB13-1PA1
Electrical data						
Operating voltage	DC 24 V via the Power Module or externally via the terminal					
Current consumption, max.	1 A from the 24 V supply					
Power loss (full load)	5.0 W plus power loss of output voltages					
Interfaces						
Digital inputs – Standard	4	4	6	6	6	6
Digital inputs – Fail-safe	–	–	1 (2 × DI)	1 (2 × DI)	3 (per 2 × DI)	3 (per 2 × DI)
	Digital inputs, electrically isolated Low <5 V, High >11 V, maximum input voltage 30 V, current consumption 5.5 mA PNP/NPN can be connected via terminals Response time: 2 ms					
Digital outputs	1	1	3 (2 × relay)	3 (2 × relay)	3 (2 × relay)	3 (2 × relay)
Analog inputs	1	1	2	2	2	2
	All analog inputs can be used as additional digital inputs.					
Analog outputs	1	1	2	2	2	2
	Analog outputs have a short-circuit protection, but they are not electrically isolated. 0 ... 10 V or 0 ... 20 mA, resolution 16 bit Response time: 4 ms					
Bus interface	RS485/USS	PROFIBUS DP	RS485/USS	PROFIBUS DP, PROFIsafe	RS485/USS	PROFIBUS DP, PROFIsafe
Encoder interfaces	–	–	–	–	–	–
PTC/KTY interface	✓	✓	✓	✓	✓	✓
Slot memory card MMC or SD card	✓	✓	✓	✓	✓	✓
Usable operator panels	BOP-2, IOP can be directly inserted					
USB interface	✓	✓	✓	✓	✓	✓
Removable connectors	✓	✓	✓	✓	✓	✓
Safety functions						
Integrated safety functions acc. to Category 3 of EN 954-1, SIL 2 acc. to IEC 61508 as well as acc. to PLd ISO 13849-1						
<input type="checkbox"/> Safe Torque Off (STO)	–	–	✓	✓	✓	✓
<input type="checkbox"/> Safe Stop 1 (SS1)	–	–	–	–	✓	✓
<input type="checkbox"/> Safely Limited Speed (SLS)	–	–	–	–	✓	✓
<input type="checkbox"/> Safe Direction (SDI)	–	–	–	–	✓	✓
<input type="checkbox"/> Safe Speed Monitoring (SSM)	–	–	–	–	–	✓
No. of SLS limit values	–	–	–	–	1	4
Safety control F-DI status via PROFIsafe	–	–	–	–	–	✓
Standards						
<input type="checkbox"/> EN 954-1 Category 3	–	–	✓	✓	✓	✓
<input type="checkbox"/> IEC 61508 SIL 2	–	–	✓	✓	✓	✓
<input type="checkbox"/> ISO 13849-1 PLd	–	–	✓	✓	✓	✓

Control Unit	CU240B-2	CU240B-2 DP	CU240E-2	CU240E-2 DP	CU240E-2 F	CU240E-2 DP-F
	6SL3244-0BB00-1BA1	6SL3244-0BB00-1PA1	6SL3244-0BB12-1BA1	6SL3244-0BB12-1PA1	6SL3244-0BB13-1BA1	6SL3244-0BB13-1PA1
Open-loop /closed-loop processes						
V/f linear / squared / parameterizable	✓	✓	✓	✓	✓	✓
V/f with flux current control (FCC)	✓	✓	✓	✓	✓	✓
Vector control, encoderless	✓	✓	✓	✓	✓	✓
Torque control, encoderless	✓	✓	✓	✓	✓	✓
Software functions						
Fixed frequencies	16, parameterizable					
Signal connection with BICO technology	✓	✓	✓	✓	✓	✓
Automatic restart following mains failure or system malfunction	✓	✓	✓	✓	✓	✓
Positioning return ramp	✓	✓	✓	✓	✓	✓
Slip compensation	✓	✓	✓	✓	✓	✓
Free function blocks (FFB) for logic and arithmetic operations	✓	✓	✓	✓	✓	✓
Ramp smoothing	✓	✓	✓	✓	✓	✓
3 switchable drive data sets	✓	✓	✓	✓	✓	✓
3 switchable command data sets (CDS) (manual/auto)	✓	✓	✓	✓	✓	✓
Flying start (flying restart)	✓	✓	✓	✓	✓	✓
JOG	✓	✓	✓	✓	✓	✓
Technology controller (PID)	✓	✓	✓	✓	✓	✓
Thermal motor protection	✓	✓	✓	✓	✓	✓
Thermal converter protection	✓	✓	✓	✓	✓	✓
Setpoint specification	✓	✓	✓	✓	✓	✓
Motor identification	✓	✓	✓	✓	✓	✓
Trace function	✓	✓	✓	✓	✓	✓
Motor holding brake	✓	✓	✓	✓	✓	✓
V _{dcm} controller	✓ (only with PM240)	✓ (only with PM240)	✓ (only with PM240)	✓ (only with PM240)	✓ (only with PM240)	✓ (only with PM240)
Kinetic buffering	✓ (only with PM240)	✓ (only with PM240)	✓ (only with PM240)	✓ (only with PM240)	✓ (only with PM240)	✓ (only with PM240)
Brake functions für <input type="checkbox"/> DC braking <input type="checkbox"/> Compound braking <input type="checkbox"/> Resistance braking with integrated brake chopper	✓ (only with PM240)	✓ (only with PM240)	✓ (only with PM240)	✓ (only with PM240)	✓ (only with PM240)	✓ (only with PM240)

Control Unit	CU240B-2	CU240B-2 DP	CU240E-2	CU240E-2 DP	CU240E-2 F	CU240E-2 DP-F
	6SL3244-0BB00-1BA1	6SL3244-0BB00-1PA1	6SL3244-0BB12-1BA1	6SL3244-0BB12-1PA1	6SL3244-0BB13-1BA1	6SL3244-0BB13-1PA1
Mechanical data and ambient conditions						
Degree of protection	IP20					
Signal cable cross-section						
<input type="checkbox"/> Min.	0.05 mm ² (AWG30)					
<input type="checkbox"/> Max.	1.5 mm ² (AWG16)					
Operating temperature	0 ... 50 °C (32 ... 122 °F)					
Storage temperature	-40 ... +70 °C (-40 ... +158 °F)					
Relative air humidity	<95 % RH, condensation not permissible					
Dimensions						
<input type="checkbox"/> Width	73 mm					
<input type="checkbox"/> Height	199 mm					
<input type="checkbox"/> Depth	46 mm					
Weight, approx.	0.49 kg					