

ATV32HU11N4

variable speed drive ATV32 - 1.1 kw - 400 V - 3 phase - with heat sink



Main

Range of product	Altivar 32
Product or component type	Variable speed drive
Product specific application	Complex machines
Assembly style	With heat sink
Component name	ATV32
EMC filter	Class C2 EMC filter integrated
Network number of phases	3 phases
[Us] rated supply voltage	380...500 V (- 15...10 %)
Motor power kW	1.1 kW at 380...500 V 3 phases
Motor power hp	1.5 hp at 380...500 V 3 phases
Line current	5 A for 380 V 3 phases 1.1 kW / 1.5 hp 3.8 A for 500 V 3 phases 1.1 kW / 1.5 hp
Apparent power	3.3 kVA at 500 V 3 phases 1.1 kW / 1.5 hp
Prospective line I _{sc}	<= 5 kA, 3 phases
Nominal output current	3 A at 4 kHz 500 V 3 phases 1.1 kW / 1.5 hp
Maximum transient current	4.5 A for 60 s 3 phases 1.1 kW / 1.5 hp
Speed drive output frequency	0.5...599 Hz
Nominal switching frequency	4 kHz
Switching frequency	2...16 kHz adjustable
Asynchronous motor control profile	Voltage/Frequency ratio, 2 points Voltage/Frequency ratio, 5 points Flux vector control without sensor - Energy Saving, NoLoad law Flux vector control without sensor, standard Voltage/Frequency ratio - Energy Saving, quadratic U/f
Type of polarization	No impedance for Modbus

Complementary

Product destination	Asynchronous motors Synchronous motors
Supply voltage limits	323...550 V
Supply frequency	50...60 Hz (- 5...5 %)
Network frequency limits	47.5...63 Hz
Speed range	1...100 for asynchronous motor in open-loop mode
Speed accuracy	+/- 10 % of nominal slip for 0.2 T _n to T _n torque variation
Torque accuracy	+/- 15 %
Transient overtorque	170...200 % of nominal motor torque
Braking torque	< 170 % with braking resistor
Synchronous motor control profile	Vector control without sensor
Regulation loop	Adjustable PID regulator
Motor slip compensation	Automatic whatever the load Not available in voltage/frequency ratio (2 or 5 points) Adjustable 0...300 %

The information provided in this documentation contains general descriptions and/or technical characteristics of the performance of the products contained herein. This documentation is not intended as a substitute for and is not to be used for determining suitability or reliability of these products for specific user applications. It is the duty of any such user or integrator to perform the appropriate and complete risk analysis, evaluation and testing of the products with respect to the relevant specific application or use thereof. Neither Schneider Electric Industries SAS nor any of its affiliates or subsidiaries shall be responsible or liable for misuse of the information contained herein.

Local signalling	1 LED red presence of drive fault 1 LED red presence of CANopen error 1 LED green presence of CANopen run 1 LED blue presence of bluetooth 1 LED red presence of drive voltage
Output voltage	\leq power supply voltage
Insulation	Electrical between power and control
Electrical connection	Power supply screw terminal 1.5...4 mm ² / AWG14...AWG10 Motor/Braking resistor removable screw terminals 1.5...2.5 mm ² / AWG14...AWG12 Control screw terminal 0.5...1.5 mm ² / AWG18...AWG14
Tightening torque	Power supply 0.6 N.m / 5.3 lb/ft Motor/Braking resistor 0.7 N.m / 7.1 lb/ft Control 0.5 N.m / 4.4 lb/ft
Supply	Internal supply for reference potentiometer (1 to 10 kOhm), 10.5 V DC +/- 5 %, \leq 10 mA for overload and short-circuit protection
Analogue input number	3
Analogue input type	AI3 current 0...20 mA (or 4-20 mA, x-20 mA, 20-x mA or other patterns by configuration), impedance 250 Ohm, resolution 10 bits AI2 bipolar differential voltage +/- 10 V DC, impedance 30000 Ohm, resolution 10 bits AI1 voltage 0...10 V DC, impedance 30000 Ohm, resolution 10 bits
Sampling duration	AO1 2 ms for analog input(s) AI1, AI2, AI3 2 ms for analog input(s)
Response time	R2A, R2C 2 ms for relay output(s) R1A, R1B, R1C 2 ms for relay output(s) LI1...LI6 8 ms, tolerance +/- 0.7 ms for logic output(s)
Accuracy	AO1 +/- 2 % for a temperature of -10...60 °C AO1 +/- 1 % for a temperature of 25 °C AI1, AI2, AI3 +/- 0.5 % for a temperature of 25 °C AI1, AI2, AI3 +/- 0.2 % for a temperature of -10...60 °C
Linearity error	AO1 +/- 0.3 % AI1, AI2, AI3 +/- 0.2...0.5 % of maximum value
Analogue output number	1
Analogue output type	AO1 software-configurable voltage 0...10 V, impedance 470 Ohm, resolution 10 bits AO1 software-configurable current 0...20 mA, impedance 800 Ohm, resolution 10 bits
Discrete output number	3
Discrete output type	LO logic R2A, R2B configurable relay logic NO, electrical durability 100000 cycles R1A, R1B, R1C configurable relay logic NO/NC, electrical durability 100000 cycles
Minimum switching current	Configurable relay logic 5 mA at 24 V DC
Maximum switching current	R2 on resistive load, 5 A at 30 V DC, cos phi = 1, R2 on resistive load, 5 A at 250 V AC, cos phi = 1, R1, R2 on inductive load, 2 A at 30 V DC, cos phi = 0.4, R1, R2 on inductive load, 2 A at 250 V AC, cos phi = 0.4, R1 on resistive load, 4 A at 30 V DC, cos phi = 1, R1 on resistive load, 3 A at 250 V AC, cos phi = 1,
Discrete input number	7
Discrete input type	STO safe torque off 24...30 V DC, impedance 1500 Ohm LI6 switch-configurable PTC probe 24...30 V DC LI5 programmable as pulse input 20 kpps 24...30 V DC, with level 1 PLC LI1...LI4 programmable (sink/source) 24...30 V DC, with level 1 PLC
Discrete input logic	LI1...LI6 positive logic (source), < 5 V (state 0), > 11 V (state 0) LI1...LI6 negative logic (sink), > 19 V (state 0), < 13 V (state 0)
Acceleration and deceleration ramps	S U CUS Deceleration ramp automatic stop DC injection Deceleration ramp adaptation Linear Ramp switching
Braking to standstill	By DC injection
Protection type	Thermal protection drive Short-circuit between motor phases drive Overheating protection drive Overcurrent between output phases and earth drive Input phase breaks drive

Communication port protocol	CANopen Modbus
Type of connector	1 RJ45 for Modbus/CANopen on front face
Physical interface	2-wire RS 485 for Modbus
Transmission frame	RTU for Modbus
Number of addresses	1...247 for Modbus 1...127 for CANopen
Method of access	Slave for CANopen
Marking	CE
Operating position	Vertical +/- 10 degree
Width	45 mm
Height	325 mm
Depth	245 mm
Product weight	2.5 kg
Option card	Communication card Profibus DP V1 Communication card Ethernet/IP Communication card DeviceNet Communication card CANopen open style Communication card CANopen daisy chain

Environment

Noise level	43 dB conforming to 86/188/EEC
Electromagnetic compatibility	Voltage dips and interruptions immunity test conforming to IEC 61000-4-11 Radiated radio-frequency electromagnetic field immunity test conforming to IEC 61000-4-3 level 3 Electrostatic discharge immunity test conforming to IEC 61000-4-2 level 3 Electrical fast transient/burst immunity test conforming to IEC 61000-4-4 level 4 Conducted radio-frequency immunity test conforming to IEC 61000-4-6 level 3 1.2/50 µs - 8/20 µs surge immunity test conforming to IEC 61000-4-5 level 3
Standards	EN 55011 class A group 1 EN 61800-3 environments 1 category C2 EN 61800-3 environments 2 category C2 EN/IEC 61800-3 EN/IEC 61800-5-1
Product certifications	CSA C-Tick GOST NOM 117 UL
Pollution degree	2 conforming to EN/IEC 61800-5-1
IP degree of protection	IP20 conforming to EN/IEC 61800-5-1
Vibration resistance	1.5 mm peak to peak (f = 3...13 Hz) conforming to EN/IEC 60068-2-6 1 gn (f = 13...200 Hz) conforming to EN/IEC 60068-2-6
Shock resistance	15 gn for 11 ms conforming to EN/IEC 60068-2-27
Relative humidity	5...95 % without dripping water conforming to IEC 60068-2-3 5...95 % without condensation conforming to IEC 60068-2-3
Ambient air temperature for operation	50...60 °C with derating factor -10...50 °C without derating
Ambient air temperature for storage	-25...70 °C
Operating altitude	1000...3000 m with current derating 1 % per 100 m <= 1000 m without derating

Offer Sustainability

Sustainable offer status	Not Green Premium product
RoHS	Compliant - since 1007 - Schneider Electric declaration of conformity
Product environmental profile	Available Download Product Environmental
Product end of life instructions	Available Download End Of Life Manual

Size A

Dimensions

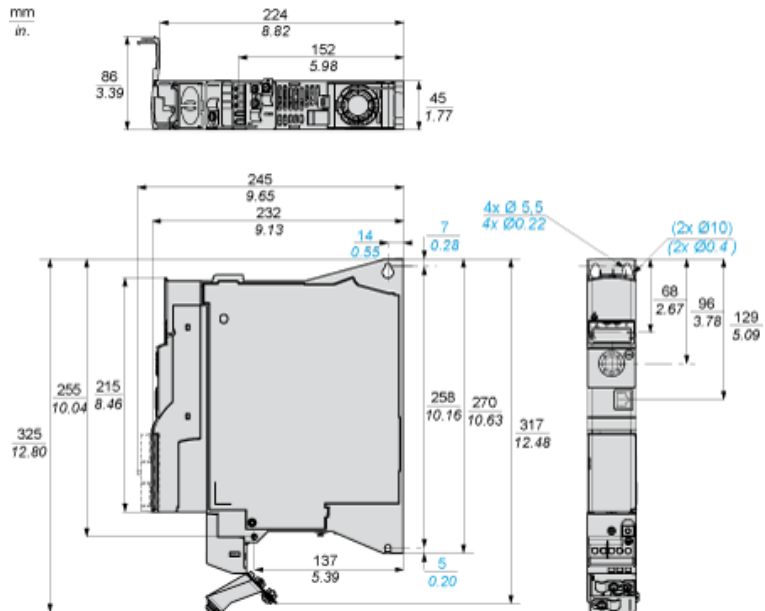

Mounting and Clearance

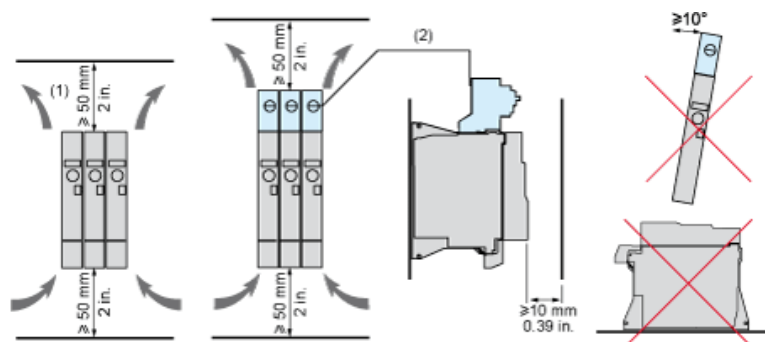

- (1) Minimum value corresponding to thermal constraints. A 150 mm clearance may help to connect the ground.
- (2) Optional GV2 circuit-breaker

Option: Protection Device, GV2 circuit-breaker

The drive is prepared to be equipped with an optional GV2 circuit-breaker.

The GV2 circuit-breaker is directly mounted on the drive. Mechanical and electrical link are made using the optional adapter. The options are supplied with detailed mounting instruction sheet.

NOTE: The product overall dimension, including GV2 adapter and EMC plate mounted, becomes 424 mm (16.7 in.)

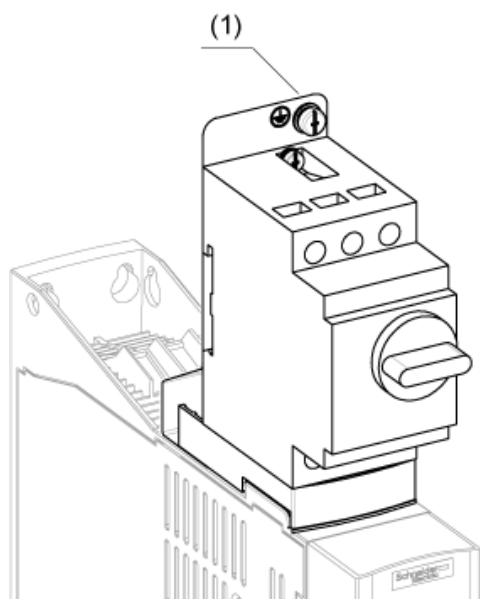

- (1) Ground screw (HS type 2 - 5x12)

Connection Diagrams

Single or Three-phase Power Supply - Diagram with Line Contactor

Connection diagrams conforming to standards EN 954-1 category 1 and IEC/EN 61508 capacity SIL1, stopping category 0 in accordance with standard IEC/EN 60204-1.

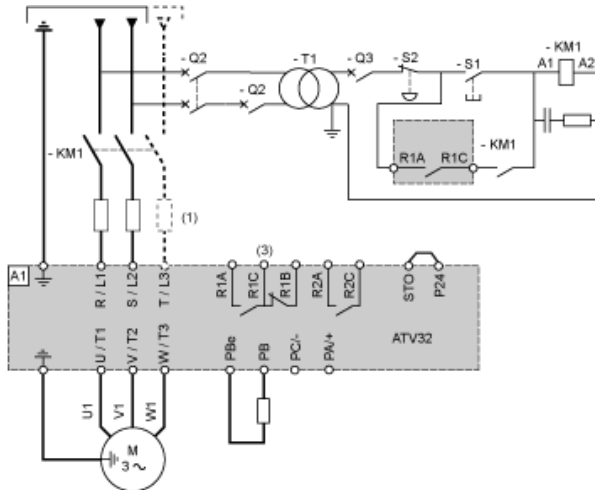

- (1) Line choke (if used)
- (3) Fault relay contacts, for remote signaling of drive status

Single or Three-phase Power Supply - Diagram with Switch Disconnect

Connection diagrams conforming to standards EN 954-1 category 1 and IEC/EN 61508 capacity SIL1, stopping category 0 in accordance with standard IEC/EN 60204-1.

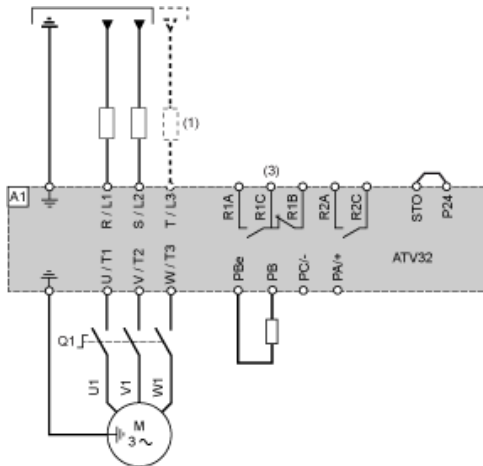

- (1) Line choke (if used)
- (3) Fault relay contacts, for remote signaling of drive status

Diagram with Preventa Safety Module (Safe Torque Off Function)

Connection diagrams conforming to standards EN 954-1 category 3 and IEC/EN 61508 capacity SIL2, stopping category 0 in accordance with standard IEC/EN 60204-1.

When the emergency stop is activated, the drive power supply is cut immediately and the motor stops in freewheel, according to category 0 of standard IEC/EN 60204-1.

A contact on the Preventa XPS AC module must be inserted in the brake control circuit to engage it safely when the STO (Safe Torque Off) safety function is activated.

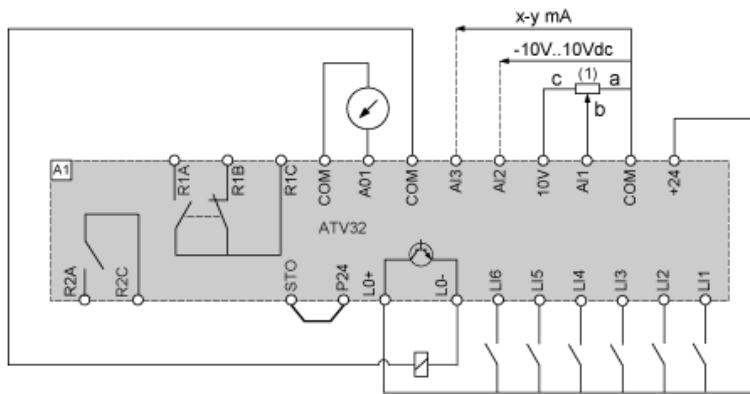

(1) Reference potentiometer SZ1RV1202 (2.2 kΩ) or similar (10 kΩ maximum)

Derating Curves

Derating curve for the nominal drive current (I_n) as a function of temperature and switching frequency.

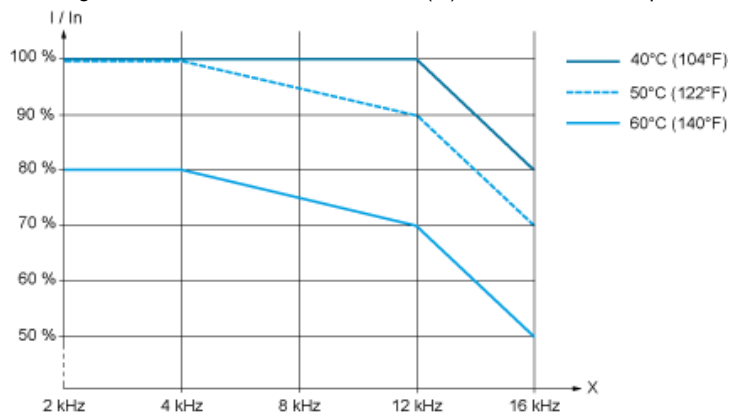

X Switching frequency

Above 4 kHz, the drive will reduce the switching frequency automatically in the event of an excessive temperature rise.

Sink / Source Switch Configuration (SW1)

The logic input switch (SW1) is used to adapt the operation of the logic inputs to the technology of the programmable controller outputs.

Switch SW1 set to "Source" position

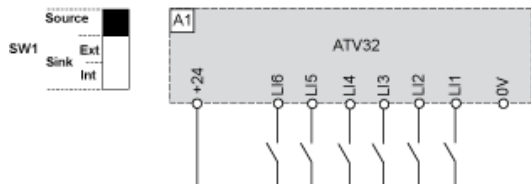

Switch SW1 set to "Source" position and use of an external power supply for the LIs

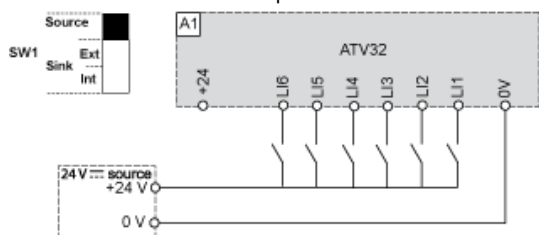

Switch SW1 set to "Sink Int" position

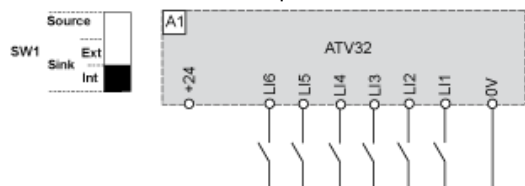

Switch SW1 set to "Sink Ext" position

