

# Auto Tuning Setting Type

## Convenient mounting, Fiber optic sensor

### ■ Features

- High speed response : Under 0.5ms
- Auto sensitivity setting (Button setting) / Remote sensitivity setting.
- External synchronization input function, Mutual interference protection, Self diagnosis function.
- Over current protection and Reverse power polarity protection.
- Timer function built in : OFF Delay approx. 40ms fixed. (Standard Type, Remote sensitivity setting type only)
- Automatically selectable Light ON / Dark ON mode.
- Able to detect small targets and mount to tiny place



**⚠ Please read "Caution for your safety" in operation manual before using.**



### ■ Specifications

Model	Standard type		External synchronization input type	Remote sensitivity setting type
	BF4RP/BF4GP	BF4R/BF4G	BF4R-E/BF4G-E	BF4R-R/BF4G-R
Response Frequency	Max. 0.5ms(FREQ.1), Max. 0.7ms(FREQ.2)			
Power voltage	12-24VDC ±10%, Ripple P-P:Max. 10%			
Current consumption	Max. 45mA			
Light source	Red LED/Green LED (Modulated)			
Sensitivity adjustment	Selectable sensitivity adjustment button			
Operation mode	Selectable sensitivity in front of this unit with ON/OFF button			
Control output	<b>PNP O · C output</b>		<b>NPN O · C output</b>	
	Load current:Max. 100mA Applied voltage:Max. 30VDC Output voltage: Min. (Power supply -2.5)VDC		Load current:Max. 100mA, Applied voltage:Max. 30VDC Residual voltage:Max. 1V (at 100mA load current), Max. 0.4V (at 16mA load current)	
Self-diagnosis output	ON state under unstable sensing (When the target stays for 300ms in unstable area), ON state when control output short-circuited			
	Load current:Max. 50mA Applied voltage:Max. 30VDC Output voltage:Min. (Power supply -2.5)VDC		Load current:Max. 50mA, Applied voltage:Max. 30VDC Residual voltage:Max. 1V (at 50mA load current), Max. 0.4V (at 16mA load current)	
Protection circuit	Short-circuit protection, Reverse polarity protection circuit			
Indicator	Operation indicator:Red LED, Stable indicator:Green LED flickers when the target stays in stable sensing area			
Emission disable input function	_____	_____	Built in	_____
External synchronization function	_____	_____	Built in (Gate/Trigger)	_____
Remote sensitivity setting function	_____	_____	_____	Built in
Interference prevention function	Built-in (Selectable FREQ.1 or FREQ.2 by ON/OFF button)			
Timer function (Selectable)	OFF delay timer (Approx. 40ms fixed)		_____	OFF delay timer (Approx. 40ms fixed)
Insulation resistance	Min. 20MΩ (at 500VDC)			
Ambient illumination	Sunlight : Max. 11,000lx, Incandescent lamp : Max. 3,000lx			
Noise strength	±240V the square wave noise (pulse width:1μs) by the noise simulator			
Dielectric strength	1,000VAC 50/60Hz for 1 minute			
Vibration	1.5mm amplitude at frequency of 10 ~ 55Hz in each of X, Y, Z directions for 2 hours			
Shock	500m/s <sup>2</sup> (50G) in X, Y, Z direction for 3 times			
Operating temperature	-10 ~ +50°C (at non-freezing status)			
Storage temperature	-20 ~ +70°C			
Ambient humidity	35 ~ 85%RH			
Material	Case : Heat-resistant ABS, Case cover : Polycarbonate			
Cable	φ 4, 4P, Length : 2m		φ 4, 6P, Length : 2m	
Approval	CE			
Weight	Approx. 65g			

※ When using a green LED, the detecting distance is 10% of red LED.

(A) Counter

(B) Timer

(C) Temp. controller

(D) Power controller

(E) Panel meter

(F) Tacho/Speed/Pulse meter

(G) Display unit

(H) Sensor controller

(I) Proximity sensor

(J) Photo electric sensor

(K) Pressure sensor

(L) Rotary encoder

(M) 5-Phase stepping motor & Driver & Controller

**Autonics**

# BF4R/BF4G Series

## Control output diagram

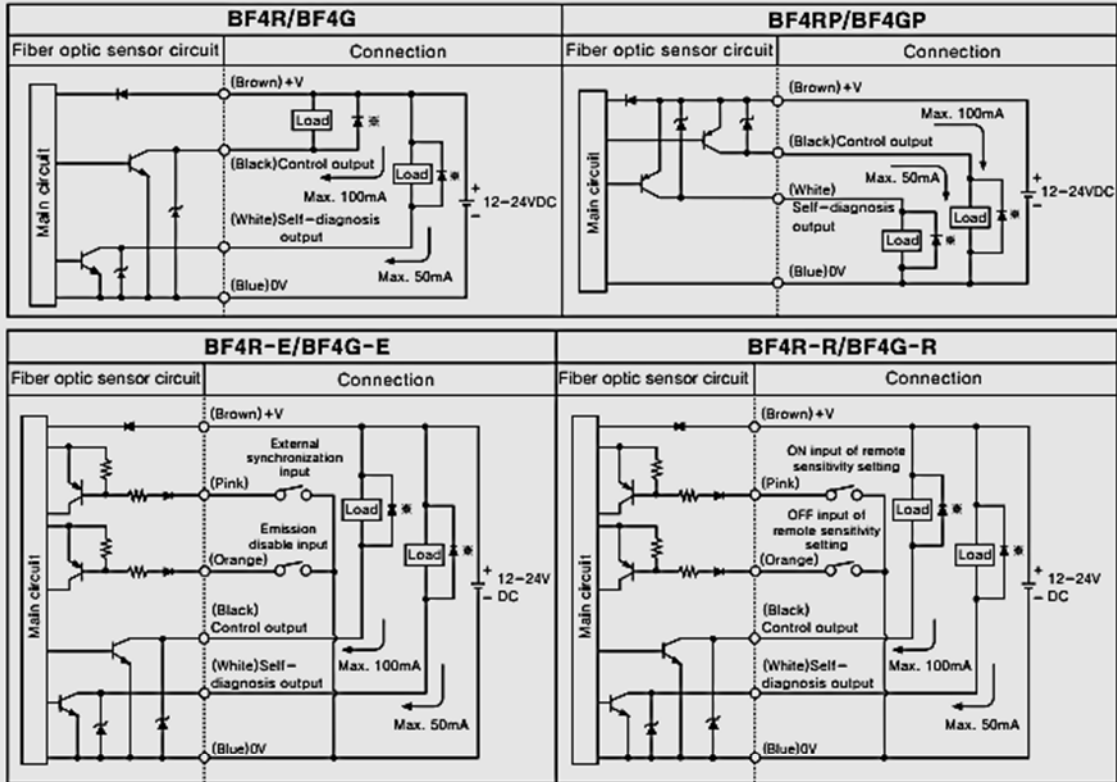

\* Connect Diode at external terminal for inductive load.

## Connections

### ●BF4R/BF4G

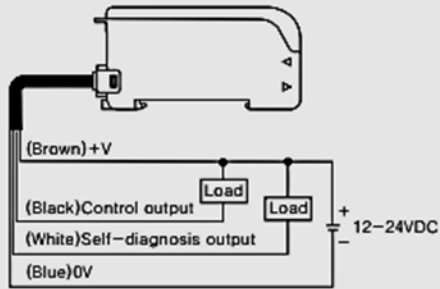

### ●BF4RP/BF4GP

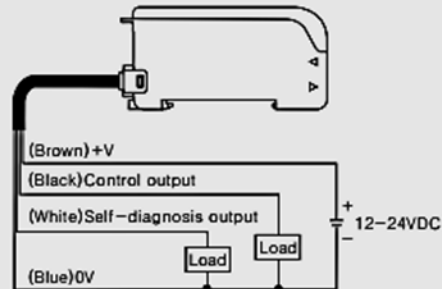

### ●BF4R-E/BF4G-E

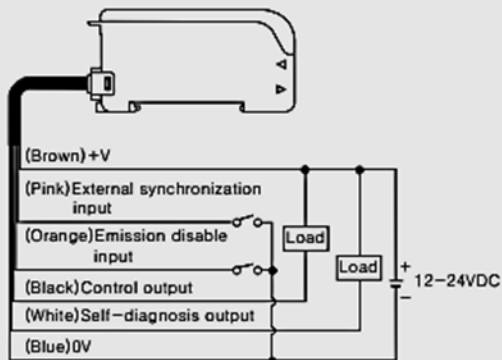

### ●BF4R-R/BF4G-R

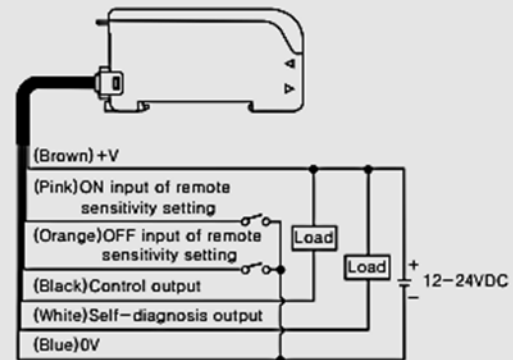

**Autonics**

# Auto Tuning Setting Type

## Dimensions

Unit:mm

### Product

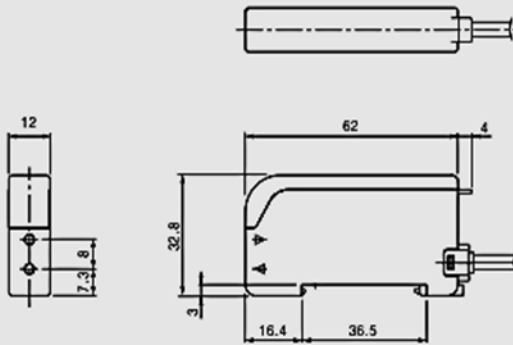

### Bracket

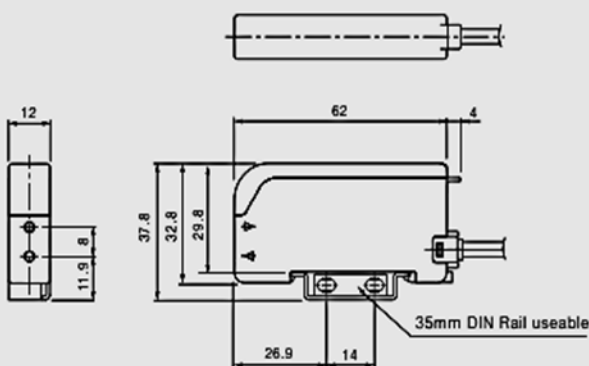

### Bracket

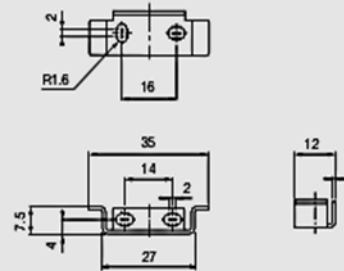

## Panel identification

### Standard type / Remote sensitivity setting type

- BF4R/BF4G, BF4RP/BF4GP/BF4R-R/BF4G-R

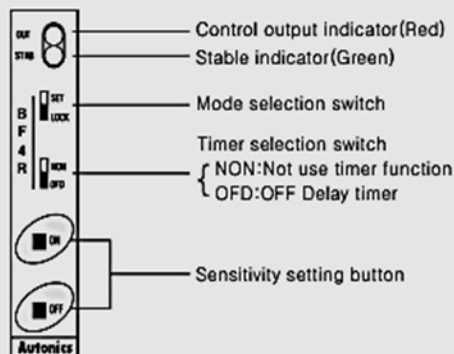

### External synchronization input type

- BF4R-E/BF4G-E

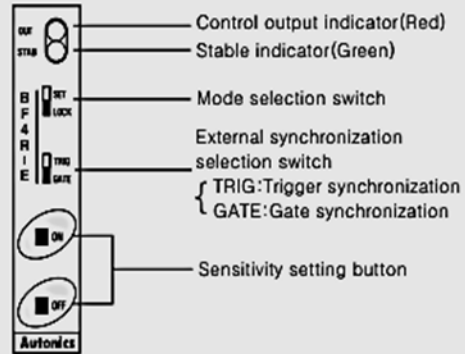

(A) Counter

(B) Timer

(C) Temp. controller

(D) Power controller

(E) Panel meter

(F) Tacho/Speed/Pulse meter

(G) Display unit

(H) Sensor controller

(I) Proximity sensor

(J) Photo electric sensor

(K) Pressure sensor

(L) Rotary encoder

(M) 5-Phase stepping motor & Driver & Controller

Autonics





# BF4R/BF4G Series

## ■ Sensitivity adjustment

### ○ Adjustment by the sensitivity setting button (All models)

#### ● Light ON Mode

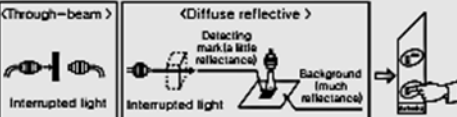
: The control output turns on at state (Received light) and turns off at State (Interrupted light).

Order	Setting method
①	Mount the fiber optic cable within detecting distance.
②	Change the mode selection switch to [SET]. 
③	Diffuse reflective: Press [ON] button with the detecting target in place. Through-beam: Press [ON] button without the detecting target. 
④	The stable indicator flickers at ON state. (Check the target position) 
⑤	Diffuse reflective: Press [OFF] button with the detecting target removed. Through-beam: Press [OFF] button with the detecting target in place. 
⑥	- When there is enough sensitivity difference between ON state and OFF state, the STAB indicator flickers one time only at stable sensing area. - When there is not enough sensitivity difference between ON state and OFF state, the STAB indicator flickers five times at unstable sensing area. (Note)
⑦	Change the mode selection switch to [LOCK], even though somebody touches the sensitivity setting button, setting sensitivity shall not be changed. 

(Note) The sensitivity can be set at unstable detecting area.

#### ● Dark ON Mode

: The control output turns off at State (Received light) and turns on at State (Interrupted light).

#### <How to set sensitivity>

Most of adjustments except ③ & ⑤ are same as Light ON mode.

#### ③ state

- Diffuse reflective : Press [ON] button without the detecting target.
- Through-beam : Press [ON] button with the detecting target.

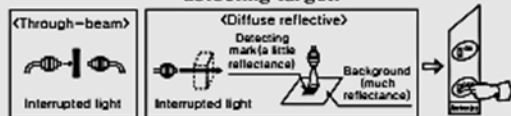

#### ⑤ state

- Diffuse reflective : Press [OFF] button with the detecting target.
- Through-beam : Press [OFF] button without the detecting target.

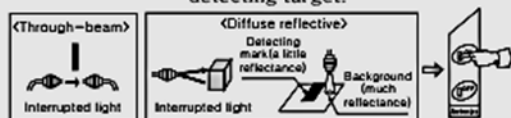

### ○ In case of setting as max. sensitivity

- ① Set the mode selection switch to [SET] mode.
- ② In case of **Light ON mode** : Press ON/OFF button from ON to OFF without the detecting target. (Or set ON input for remote sensitivity setting to Low level, and then set OFF input for remote sensitivity setting to Low level)  
In case of **Dark ON mode** : Press ON/OFF button from OFF to ON without the detecting target. (Or set OFF input for remote sensitivity setting to Low level, and then set ON input for remote sensitivity setting to Low level)
- ③ Set the mode selection switch to [LOCK] mode.

#### ※ External sensitivity setting

- **Light ON Mode** (From above ③)  
External sensitivity setting ON input (High→Low→High).  
External sensitivity setting OFF input (High→Low→High)
- **Dark ON Mode** (From above ③)  
External sensitivity setting OFF input (High→Low→High).  
External sensitivity setting ON input (High→Low→High)

#### <Application >

- In case of extend detecting distance as the diffusive reflection type :  
If using one fiber optic sensor in place where there are targets with high reflectivity and low reflectivity, able to get stable detection by adjusting max. sensitivity.
- In case of using the through-beam type at bad environment :  
If using fiber optic sensor in place where there is lots of dust or moisture it might cause malfunction. Please max. sensitivity then it can perform stable detection.

### ○ Remote adjustment of sensitivity (BF4R-R/BF4G-R)

BF4R-R/BF4G-R type can adjust the sensitivity with input signal lines regardless of the mode selection switch as following diagram:

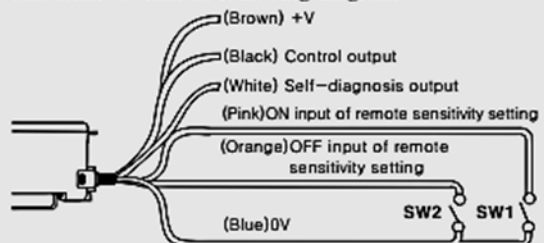

- ① SW1 (ON input of remote sensitivity setting) : SW1 turns on and then turns off instead of ③ method by the sensitivity setting button.
- ② SW2 (OFF input of remote sensitivity setting) : SW2 turns on and then turns off instead of ⑤ method by the sensitivity setting button.

#### <External sensitivity setting input signal condition>

State	Signal condition
High	4.5-30VDC or OPEN
Low	0-1VDC

• Input impedance: 10kΩ

**Autonics**

# Auto Tuning Setting Type

## External sensitivity setting input prohibition (BF4R-R/BF4G-R)

Even though mode switch is at Lock position, External sensitivity setting input is possible when SW1 and SW2 are ON. Therefore please install SW3 in order to prevent sfrom malfunction as below.

- SW3 – OFF : Disable to set external sensitivity
- SW3 – ON : Enable to set external sensitivity

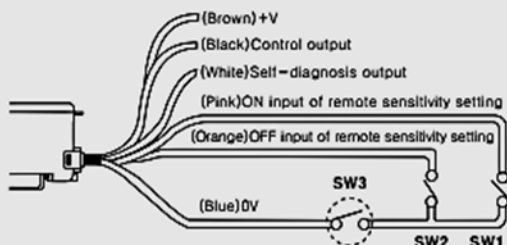

## Answer Back function(BF4R-R/ BF4G-R only)

When ON or OFF input of remote sensitivity setting is applied, after 300ms, self-diagnosis output turns on for 40ms and then the sensor keeps normal detecting state. (Note:Time chart)

\*Self-diagnosis output does not turn on if there is no difference of sensitivity between ON input and OFF input and stable sensing is not executed, but stable sensing operates after 340ms.

<Time Chart : Light ON Mode >

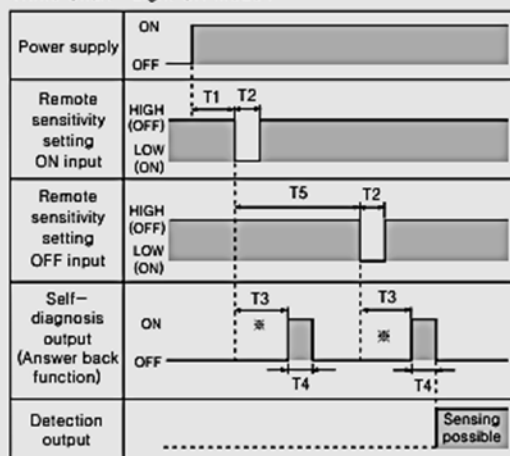

※During period T3(Approx. 300ms), do not change the received light value by moving the object, etc.

1. T1 ≥ 1,000ms (After the power turns on, it can be set after 1 sec.)
2. T2 ≥ 5ms (ON or OFF input time of remote sensitivity setting must be min. 5mS)
3. T3 ≈ 300ms (When ON or OFF input of remote sensitivity setting is applied, self-diagnosis output turns on after 300ms)
4. T4 ≈ 40ms (ON time of self-diagnosis output)
5. T5 ≥ 500ms (When ON input of remote sensitivity setting is applied and then apply OFF input of remote sensitivity setting after 500ms)

## OFF Delay timer function (BF4R/BFGR/BF4RP/BF4GP/BF4R-R /BF4G-R only)

Standard type (BF4R/BF4G/BF4RP/BF4GP) and Remote sensitivity setting type (BF4R-R/BF4G-R) both contain a built-in approx. 40ms fixed OFF-delay timer. The timer works when the timer selection switch is set to 'OFD'. The output turns off after remaining on for additional 40ms at OFF position of the sensing output. It is useful when the response time of the connected device is slow or when the sensing signal from a tiny object is too short.

<Time chart >

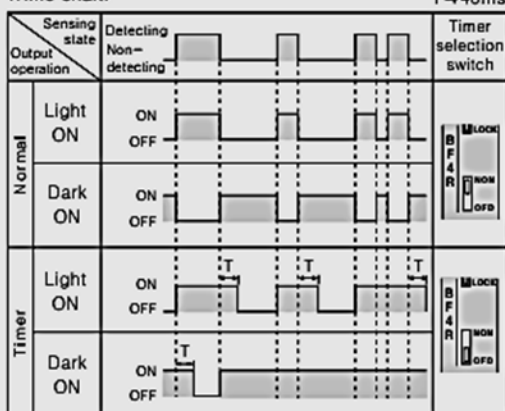

## External synchronization input function(BF4R-E/BF4G-E)

By using external synchronization function, the time for making detection can be specified by External synchronization. Trigger synchronization and gate synchronization are available.

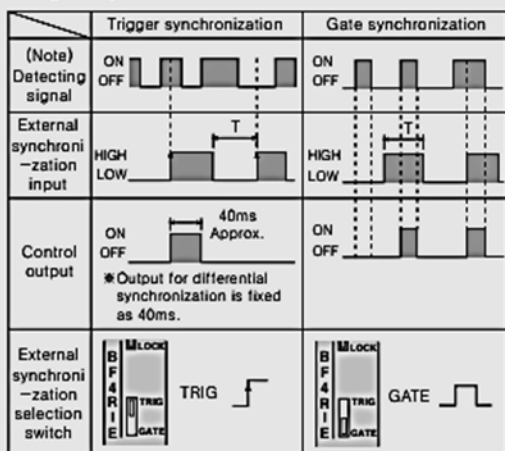

※T ≥ 0.5ms (When using interference prevention function : T ≥ 0.7ms)

(Note) Actual signal detected by sensor.

<Input signal condition for External synchronization >

State	Signal condition
High	4.5-30VDC or Open
Low	0-1VDC

- (A) Counter
- (B) Timer
- (C) Temp. controller
- (D) Power controller
- (E) Panel meter
- (F) Tacho/ Speed/ Pulse meter
- (G) Display unit
- (H) Sensor controller
- (I) Proximity sensor
- (J) Photo electric sensor
- (K) Pressure sensor
- (L) Rotary encoder
- (M) 5-Phase stepping motor & Driver & Controller

# BF4R/BF4G Series

## ■ Emission disable function (BF4R-E/BF4G-E)-Operation Test

- Below test is available under Light ON state only.
- If Emission disable input is at Low state, Emission light will be disabled.
- It can check normal or abnormal state of the sensor without moving the target.

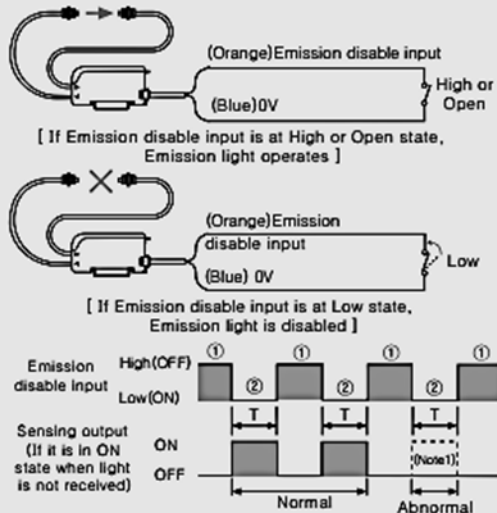

- ※ ① : Emission area, ② : Emission stopped area
- ※ (Note1) If Emission stops, control output must turn on, but if control output does not turn on, it seems that sensor has some problems.
- ※  $T \geq 0.5ms$   
(When using interference prevention function  $T \geq 0.7ms$ )
- ※ Emission disable input High: 4.5–30VDC or Open  
Low : 0–1VDC

## ■ Self-diagnosis function(All models)

When fiber tip is covered with dust, there will be reduction in emitted or received light which will cause the self-diagnosis output to turn on.

※ Light ON mode

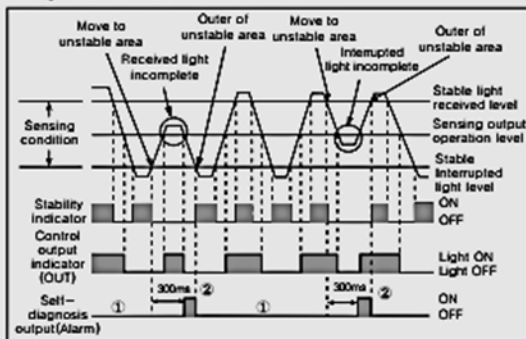

- ① The self-diagnosis output turns off during stable sensing. (① position)
- ② When detecting state remains for 300ms at unstable area between stable interrupted light level and stable received light level, self-diagnosis output turns on, self-diagnosis output turns off at lower than stable interrupted light level and upper than stable received light level. (② position)
- ③ When the control output turns on, if an over-current condition exists in control output, then self-diagnosis output turns on.

## ■ Interference prevention function (All models)

BF4R series have a built-in interference prevention function, two fiber optic cables can be mounted very closely by setting different emission frequencies.

### ● Interference prevention function (Operation of dual frequency mode)

First sensor—FREQ.1 (Response time:Max. 0.5ms)

- ① Set the mode selection switch to [SET].



- ② Press [ON] & [OFF] buttons for 2sec. at the same time.
- ③ The [STAB] indicator flickers continuously.
- ④ Press [ON] button
- ⑤ The [STAB] indicator turns off.

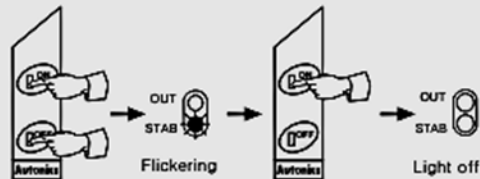

- ⑥ Set the mode selection switch to [LOCK].



Second sensor—FREQ.2 (Response time:Max. 0.7ms)

- ① Set the mode selection switch to [SET].



- ② Press [ON] & [OFF] buttons for 2sec. at the same time.
- ③ The [STAB] indicator flickers continuously.
- ④ Press [OFF] button
- ⑤ The [STAB] indicator turns off.



- ⑥ Set the mode selection switch to [LOCK].



### ● Interference prevention function(Operation of normal mode)

- ① Set the mode selection switch to [SET].
  - ② Press [ON] & [OFF] buttons for 2 sec. at the same time.
  - ③ The stable indicator flickers continuously.
  - ④ Press [ON] & [OFF] buttons at the same time.
  - ⑤ The [STAB] indicator turns off.
  - ⑥ Set the mode selection switch to [LOCK].
- ※ In case of using interference prevention function, hysteresis & response time will be longer than normal operation (response time:Max. 0.5ms).