



NQ3
- Arrancadores directos IP55 en caja de base metálica y tapa plástica

1. General

1.1 El arrancador serie NQ3 se utiliza principalmente en circuitos de corriente alterna de 50/60Hz, tensión nominal de servicio de 690V y potencia de control nominal de hasta 11kW (hasta 22A) para controlar el arranque y parada directos del motor, y protegerlos contra fallos de fase y sobrecargas.

1.2 Norma: UNE-EN60947-4-1

2. Designación de modelo



3. Características generales

Altitud: no superior a 2000m.
 Temperatura del aire ambiente: -5°C~+40°C
 Tensión nominal (50Hz ca): 36V、110V、230V、400V.
 Vida mecánica: 1.000.000 ciclos.
 Vida eléctrica: 500.000 ciclos

Tabla 1 - Modelos básicos y características técnicas de los arrancadores

Modelo	Corriente de nominal (A)	Potencia nominal máx. (kW)			Modelo del contactor a montar	Modelo de relé a montar	Rango de ajuste del relé (A)
		AC-3					
		660V	380V	220V			
NQ3-5.5P	12	7.5	5.5	3	NC1-1810	NR2-25	0.1~0.16 0.16~0.25 0.25~0.4 0.4~0.63 0.63~1 1~1.6 1.25~2 1.6~2.5 2.5~4 4~6 5.5~8 7~10 9~13
NQ3-11P	22	22	11	5.5	NC1-3210		12~18 17~25

4. Dimensiones generales y de montaje (mm)

NQ3-5.5P

NQ3-11P

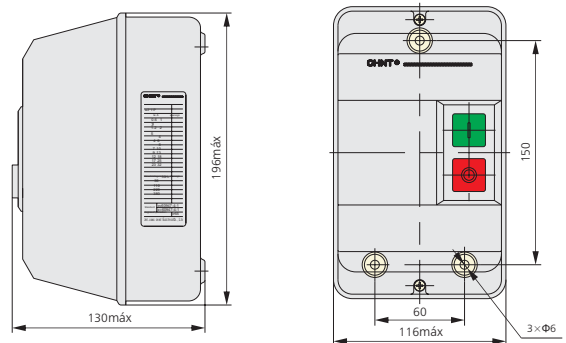
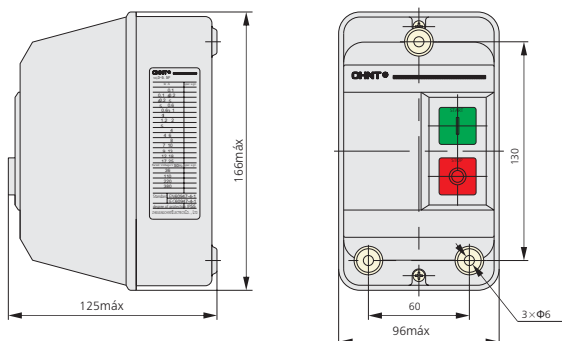

5. Esquemas de conexiones

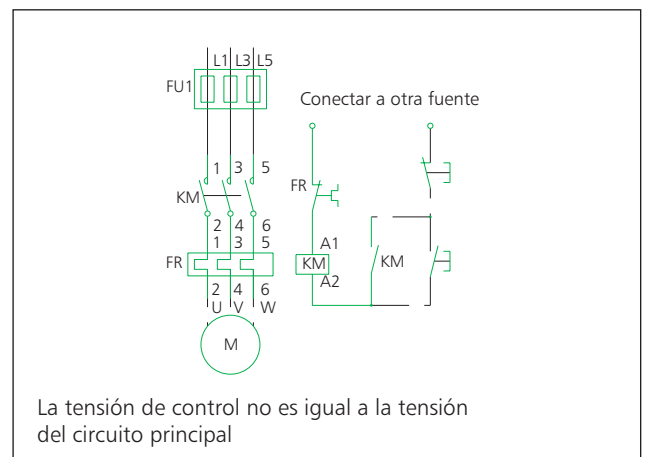
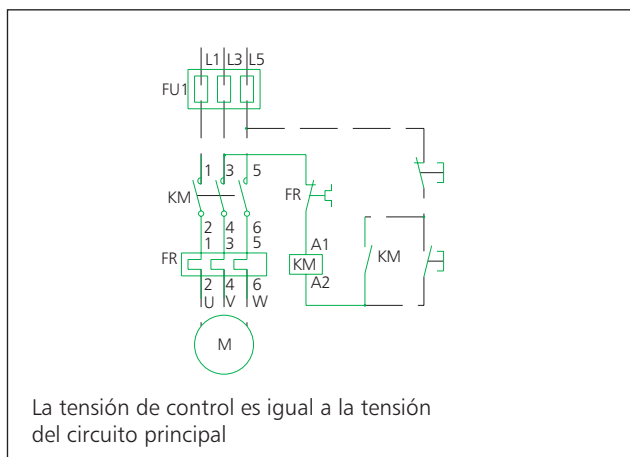

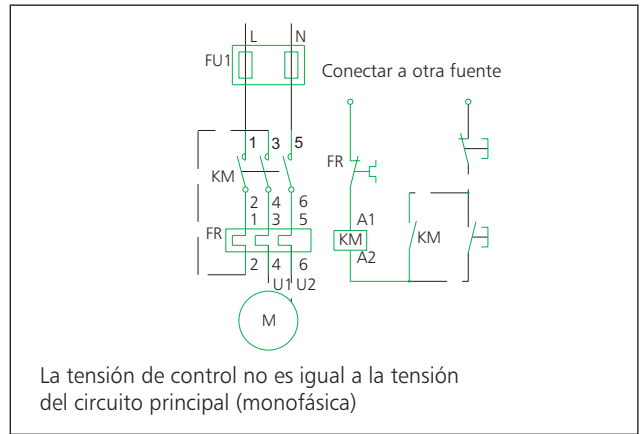
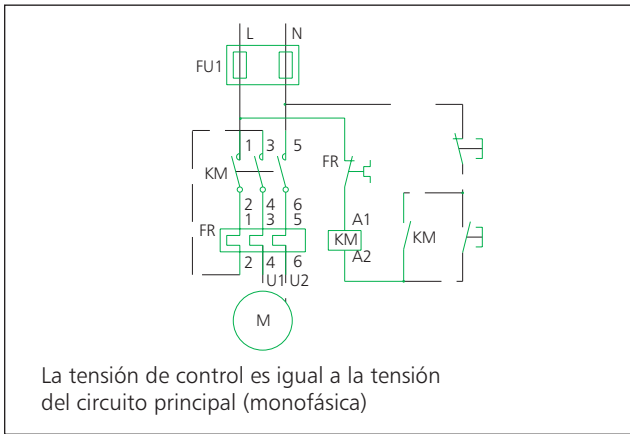

6. Fotografías

NQ3-5.5P



NQ3-11P

